

  
heating systems

Distributor: CALOR SRL  
Str. Progresului nr. 30-40, sector 5, Bucuresti  
tel: 021.411.44.44, fax: 021.411.36.14  
[www.calorserv.ro](http://www.calorserv.ro) - [www.calor.ro](http://www.calor.ro)



# OM SERIES

## ASSEMBLING MANUAL

CAST BODY ASSEMBLING DETAILS

CABIN SHEETS ASSEMBLING DETAILS

## **OM SERIES CAST IRON BOILERS INSTALLATION SPECIFICATIONS :**

This installation manual is prepared for licensed and certified installation and service technicians in domestic and international markets and for perfect cast iron boiler installation.

It is obvious that technicians must provide safety and security conditions before and during installation process. Technicians must pay attention while they are carrying heavy cast iron boiler sections before and during assembly and installation process for preventing health injuries.

Boiler room and boiler platform must be controlled before starting to installation process. If the conditions are inconvenient do not start the installation process until all conditions are convenient.

Please read, study and understand this manual before starting the installation process.

Installation components and equipments are provided with the boilers. Assembly silicone, silicone cartridge, nipple, gloves and dust mask is provided with assembling equipments.

Do not damage boiler body and cabins painting during and after installation process and during burner and system - chimney connection process and warn other technicians for this matter.

Please ask for help from producer or sales company technical departments if any questions occur in your mind during installation process.

Minimum 2 persons are required for OM series cast iron boilers installation.

Do not forget that correctly installed boiler will work properly for long time.

We thank you for reading these warnings and suggestions and wish you a successful installation.

RIMA HEATING SYSTEMS

Boiler assembly chassis ( as tooled side looking at back and top ) must be installed on to the concrete platform.

Concrete platform must be flat for keeping the boiler in balance.



Back section of the boiler must be positioned on to the chassis in upright position. Holes on the chassis must be positioned as opposite to the assembling holes on the back section, then must be screwed with 4 pcs of M12x50 mm nuts for stabilizing on back section.

**\*\*\* For easy assembly nuts head must be at bottom and bolt pins must be at top side.**

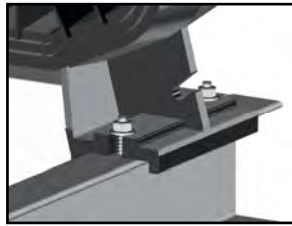

Back section smoke leakage proof channels must be cleared with a brush or with a piece of clothe and silicone must be filled in it afterwards.

Prepared smoke leakproof isolation rope must be stuck in that channel like in the picture with the help of silicone which is already filled.

Leakproof gaskets must be installed on axis nipple and axis nipple must be installed to nipple axis hole.

**\*\*\* For easier assembly , silicone can be used for preventing o-ring and nipple to fall down .**



**\*\*\* For easier assembly, stick leakproof isolation ropes on to the channels on cast iron sections before starting section assembly process.**

**\*\*\* Leakproof isolation ropes must be installed exactly in the channels.**

**\*\*\* There must not be any empty spaces in the connection points of leakproof isolation ropes.**



After installing leakproof isolation rope, axis nipple, o ring to back section it must be installed by sliding the middle section on the chassis.

**\*\*\* The middle section which has thermostat hole must be used as the second middle section before the front section. ( Section number 3 )**

M10 x 240 section assembling rods must be connected to assembling ears and foot in balance and middle section must be connected to back section.

**\*\*\* Section assembling rods are for the assembling of the sections. They are not for preventing leakages.**



Same process must be repeated according to the capacity ( middle section quantity ) of the boiler. Middle section assemblies must be done in the same way.



After middle sections assembling same process must be applied to front section for front section assembly.

**\*\*\* The rope which is installed to last middle section smoke leakproof channel ( the middle section before the front section) can not be installed to the channel between 2nd and 3rd passes.**

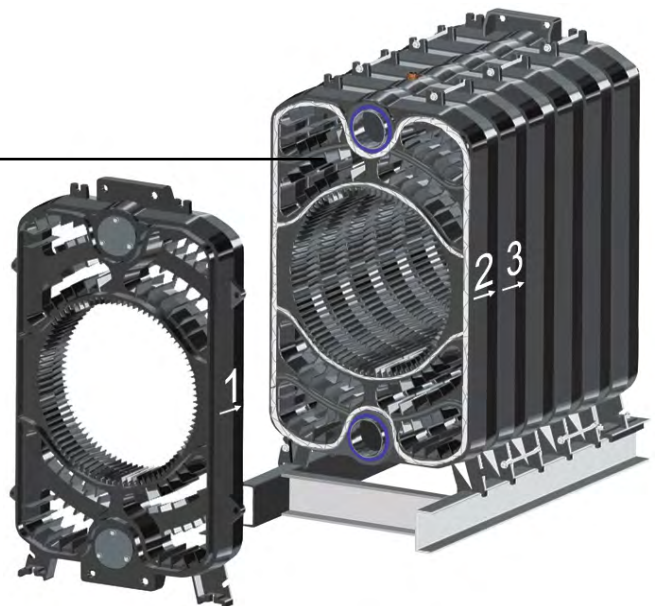

Boiler assembly rods must be connected after all sections assembly process is finished.

4 pcs of assembling rods must be connected to the boiler, stabilization holes which are on front and back sections of the boilers. Nuts and bolts must be installed in cross ways and must be screwed in balance.

Screwing torque : 6 kgm

**\*\*\* Section assembly rods must not be taken off .  
These rods will be used on cabin assembly.**

Expansion Springs Assembly :

4 pcs of boiler assembly rods in the front and nuts must be taken off one by one and expansion springs must be connected in cross way. Than nuts and bolts must be screwed again.

For screwing torque control : 3 kgm

**\*\*\* Expansion springs assembly must be done one by one and in cross ways.**

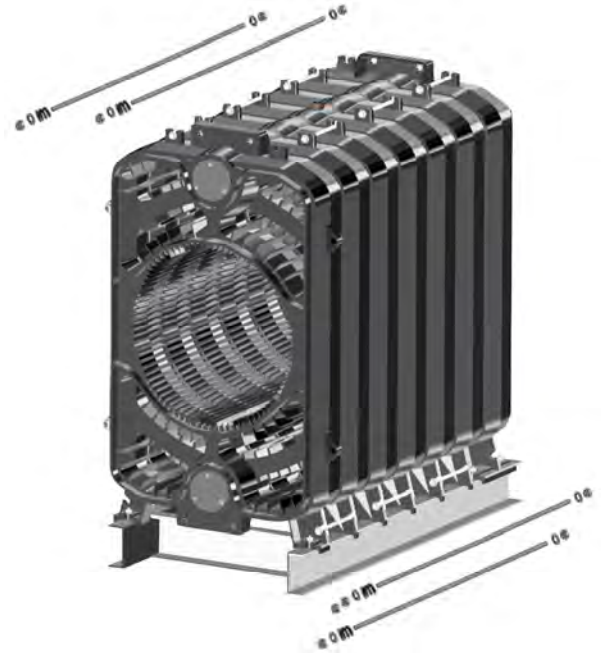

Boiler assembly expansion springs assembly must be done as seen in the figure on top ; with nuts and bolts.

Spring joints distance must be approximately 0,5 mm.

After section assembly and boiler assembly rods assembly boiler back chimney door and water input - output adaptors must be installed.



Boiler back chimney door must be installed and must be screwed with 4 pcs of M12 x 95 rods for preventing the leakage.

Water input- output adaptors must be installed by connecting washers and, must be screwed with 4 pieces of bolts for preventing leakage.

**\*\*\* Water input adaptor must be installed (adaptor at bottom ) as 1 1/2" releasing valve shows bottom or side ways.**

**\*\*\* Water input adaptor must be installed with connecting washer, pipe with flange, washer and adaptor in a row.**

**\*\*\* 1 1/2" output of output adaptor must show top or side ways.**

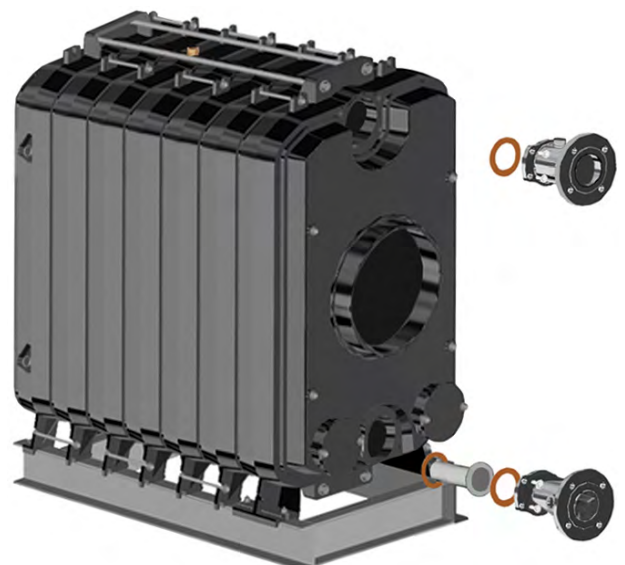



After installation of boiler input and output adaptors, boiler must be tested for leakage by filling water inside without connecting the front burner door ,for 10 minutes under 9 bars pressure .

**Test Result :**

If any leakage is spotted boiler must be repaired by exploring the spot. If there are no leakages,flame delayer turbulators assembly process must be started.



- 1** Boiler Burning Gas ( 1. Pass )
- 2** Boiler Burning Gas ( 2. Pass )
- 3** Boiler Burning Gas ( 3. Pass )

1. Install the flame delayer turbulators to the channels as seen on table.

**\*\*\* Small turbulators must be installed to 2nd passes and 2 pieces for each .Big turbulators must be installed to 3rd passes.**

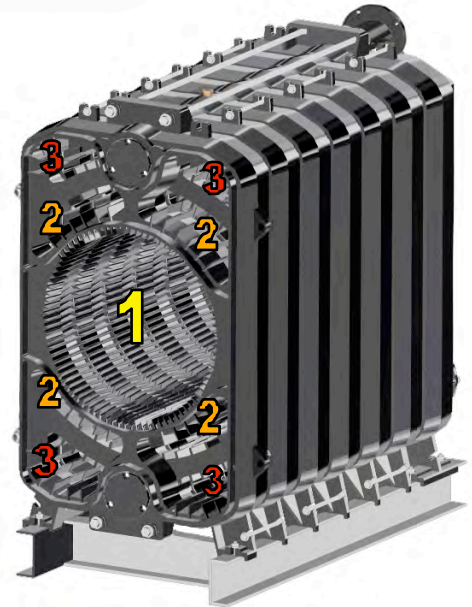

Turbulators must be installed to passage channels from front section.

**Table - 1 Flame Delayer Turbulator Installation Table :**

Boiler Model	OM-06	OM-07	OM-08	OM-09
Second pass	1+1+1+1	1+1+1+1	1+1+1+1	1+1+1+1
Third pass	1+1+1+1	1+1+1+1	1+1+1+1	1+1+1+1

Boiler Model	OM -10	OM-11	OM-12	OM-13
Second pass	1+1+1+1	1+1+1+1	1+1+1+1	1+1+1+1
Third pass	1+1+1+1	1+1+1+1	1+1+1+1	None

Boiler Model	OM-14	OM 15-16
Second pass	1+1+1+1	None
Third pass	None	None

**\*\*\* Turbulators must be connected through the middle of the front section.**

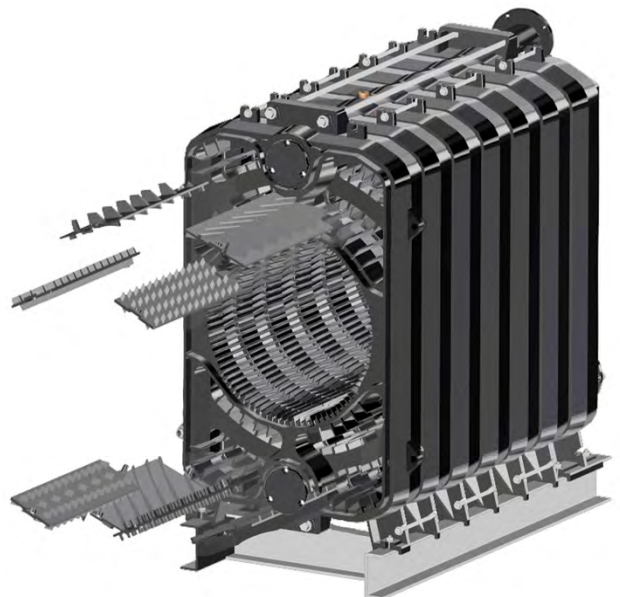

After the installation of the turbulators to the passes boiler burner door must be connected to front section.

4 hinges which are connected to front section, must be connected to the hinge arms on the burner door.

Connect M10 x 80 mm hinge bolts according to your desire for opening side according to plumbing connections and boiler room.

After connecting bolts 4 pcs M16 nuts and pins must be connected and screwed in balance.

**\*\*\* There must be no gap between the burner door and front section for preventing smoke leakage.**

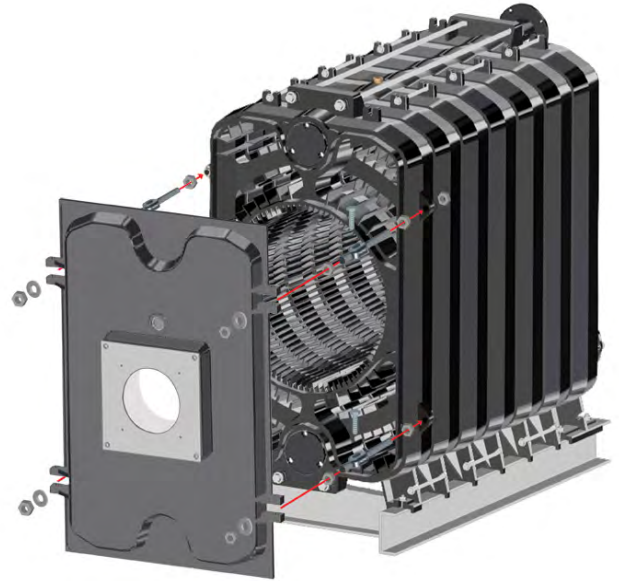

After body assembly and leakage tests blakite® - which is given with assembling parts - must be applied between the sections for preventing smoke leakage.



For cabin sheets installation cabin assembly legs must be connected to rods on the boiler legs.

Cabin sheet assembly legs must be connected to the rods which we have used for sections connections, as shown in the picture. Then the rods must be screwed.

**Table - 2 Assembling Leg Table :**

Boiler Model	Cabin Assembly Detail	Cabin Length	Cabin Ass. Leg Qty.	Section Numbers For Connecting Ass. Legs
OM-06	6	1090	4	1. 2. + 5. 6.
OM-07	4+3	1250	6	1. 2. + 4. 5. + 6. 7.
OM-08	4+4	1410	6	1. 2. + 4. 5. + 7. 8.
OM-09	4+5	1570	6	1. 2. + 4. 5. + 8. 9.
OM-10	5+5	1730	6	1. 2. + 5. 6. + 9. 10.
OM-11	6+5	1890	6	1. 2. + 6. 7. + 10. 11.
OM-12	4+MIDDLE+3	2050	8	1. 2.+ 4. 5.+ 9. 10.+ 11.12.
OM-13	5+MIDDLE+3	2210	8	1. 2. + 5. 6.+ 10.11.+ 12.13.
OM-14	5+MIDDLE+4	2370	8	1. 2.+ 5. 6. + 10.11.+ 13.14.
OM-15	5+MIDDLE+5	2530	8	1. 2. + 5. 6. + 10. 11.+ 14.15.
OM-16	6+MIDDLE+5	2690	8	1. 2. + 6. 7. + 11.12. + 15.16.

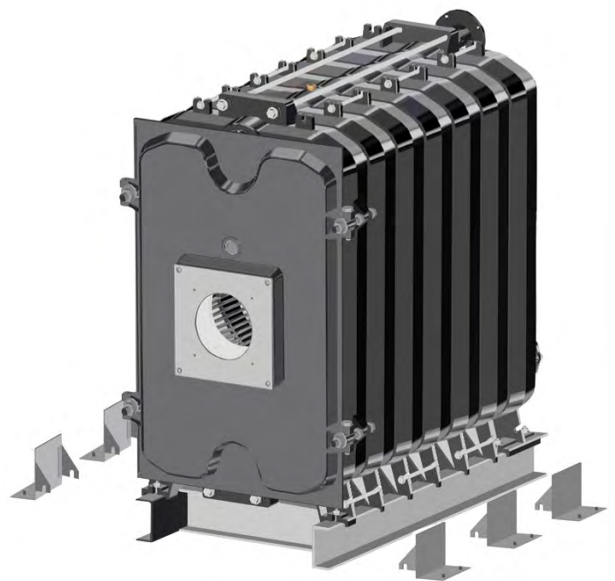

\*\*\* Selection of section legs and cabin sheet assembly legs is shown in table 2.

After connection of cabin sheet assembly legs in both sides of the boiler body, cabin sheet assembly ears on top of the boiler body must be connected to their places.

\*\*\* If there are no assembling rods on the section which assembly legs and ears will be connected, these rods can be taken from other sections .

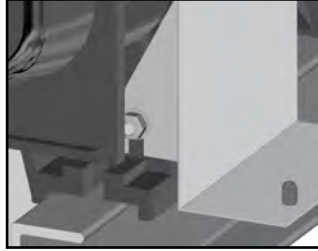
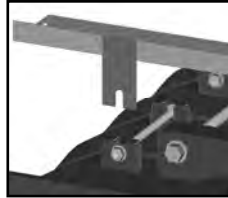

Table - 3 Assembly Ear Table :

Boiler Model	Cabin Ass. Detail	Cabin Length	Cabin Sheet Ass. Ear Qty.	Section Numbers For Connecting Ass. Ears
OM-06	6	1090	2	FRONT SEC. + BACK SEC.
OM-07	4+3	1250	3	FRONT S. + 4. 5. + BACK S.
OM-08	4+4	1410	3	FRONT S. + 4. 5. + BACK S.
OM-09	4+5	1570	3	FRONT S. + 4. 5. + BACK S.
OM-10	5+5	1730	3	FRONT S. + 5. 6. + BACK S.
OM-11	6+5	1890	3	FRONT S. + 6. 7. + BACK S.
OM-12	4+MIDDLE+3	2050	4	F. S. + 4. 5. + 9. 10. + B. S.
OM-13	5+MIDDLE+3	2210	4	F. S. + 5. 6. + 10. 11. + B. S.
OM-14	5+MIDDLE+4	2370	4	F. S. + 5. 6. + 10. 11. + B. S.
OM-15	5+MIDDLE+5	2530	4	F. S. + 5. 6. + 10. 11. + B. S.
OM-16	6+MIDDLE+5	2690	4	F. S. + 6. 7. + 11. 12. + B. S.

Cabin sheet assembly ears must be connected to the assembly rods on top side as seen in the picture. Then, nuts must be screwed with a light force for holding the piece.



After the installation of the cabin sheet assembling legs and ears , body insulation and cabin sheets must be installed on the body.





8 cm body isolation must be prepared according to boiler dimensions and installed on the boiler body.



Isolation must be cut around assembling ears connection points.

Body insulation must be cut for opening thermostat socket.

Isolation must be connected with a stainless steel wire from 2 points to the body for stabilization.



First the holes on the side cabin sheets must be connected to the pins on the assembly legs and then must be connected to cabin sheet assembly ears with M8 x 20 bolts as seen in the picture.

Same process must be applied to additional right and left cabin sheets for their installation to the boiler body.

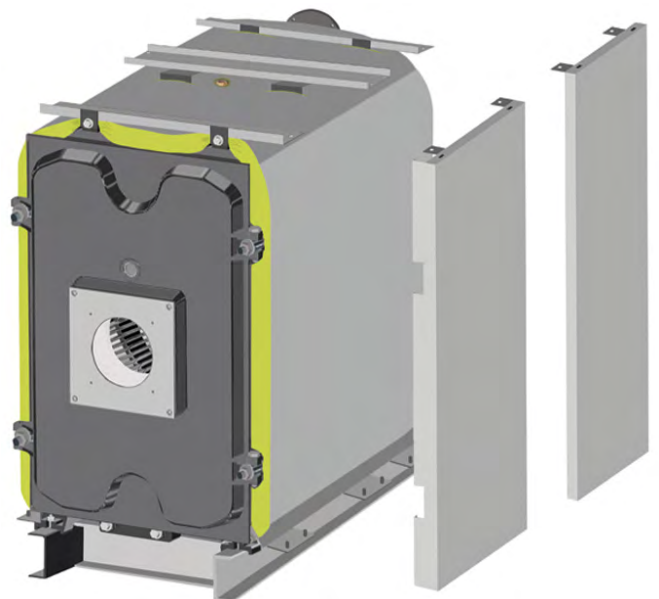
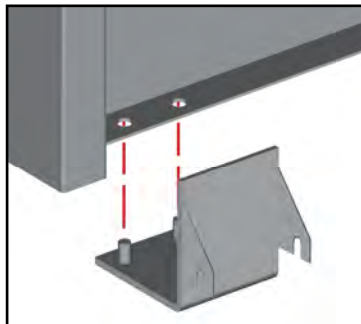

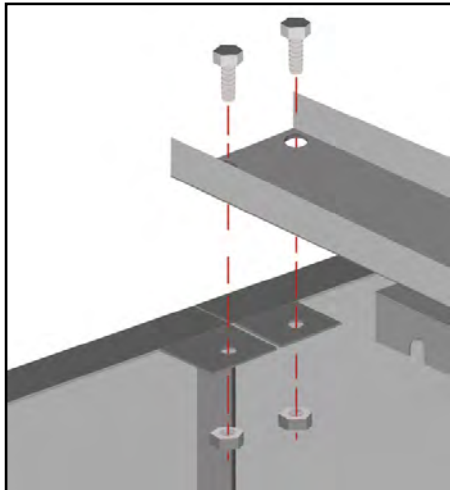
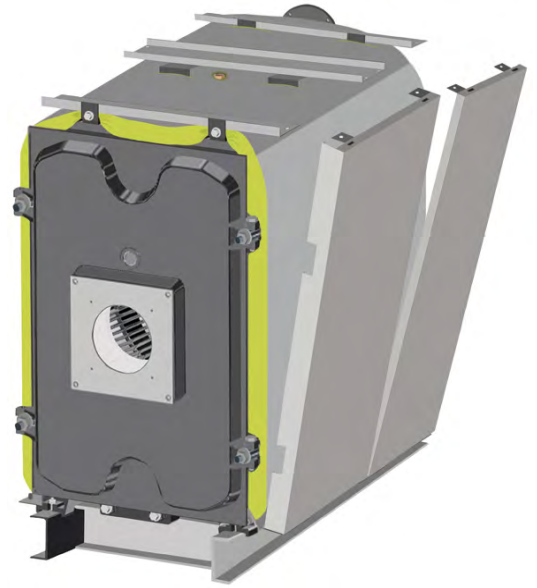
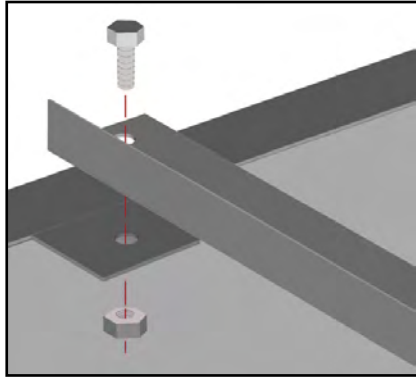

After installation of side cabins control panel must be connected on to the front top cabin sheet.



There are three holes on the front cabin sheet. Thermocouples ( sensors) of the control panel ( thermostat,safety thermostat, thermometer ) must be passed through the middle hole. Control panel must be stabilized to the holes on right and left.

After installing sensors edges inside the socket segment must be plugged for preventing the sensor edges to move out.

**\*\*\* Oil which is given with the assembling parts,must be filled to thermostat hole for increasing the sensitivity of the sensors.**



After these processes pins on the top cabin must be connected to segments on side cabins.

Extra top cabin must be installed by connecting to the segments on side cabins.



After side and top cabin sheet assembly, back cabin sheet must be installed.



Back cabin sheet isolation must be installed and back sheet must be connected to the side cabins ( as the open side shows upside ) with cabin connection screws as shown in the picture. ( 4 pcs. for right , 4 pcs. for left and 3 pcs. for the middle connection point. )

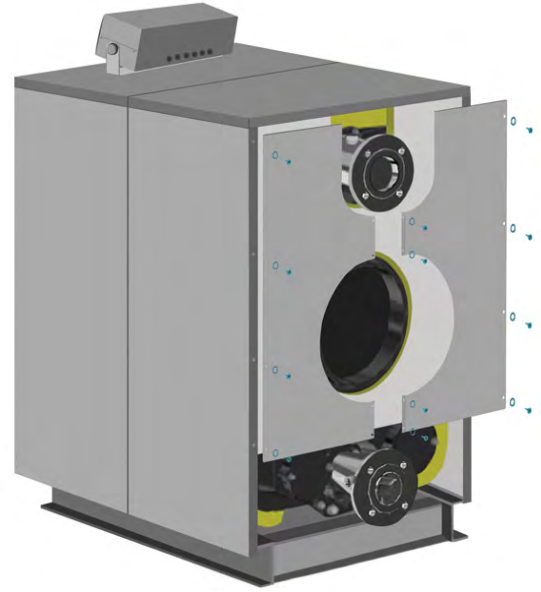

As back cabin sheet installation completes, all cabin parts installation is finishes.



Then the boiler is ready for burner installation, system and chimney connections.

**\*\*\* Burner installation, chimney and system connections must be done according to the standards and in attention with specifications in operation and maintenance manuals and by authorized technicians.**

